

OPERATION, MAINTENANCE & REPAIR MANUAL  
**MEDICAL GAS  
OUTLET STATIONS**  
500/560 Series

Form Number 64-00-2008  
(S168-154-001)

APRIL 1993

**Allied Healthcare  
Products, Inc.**  
CHEMETRON Medical Division

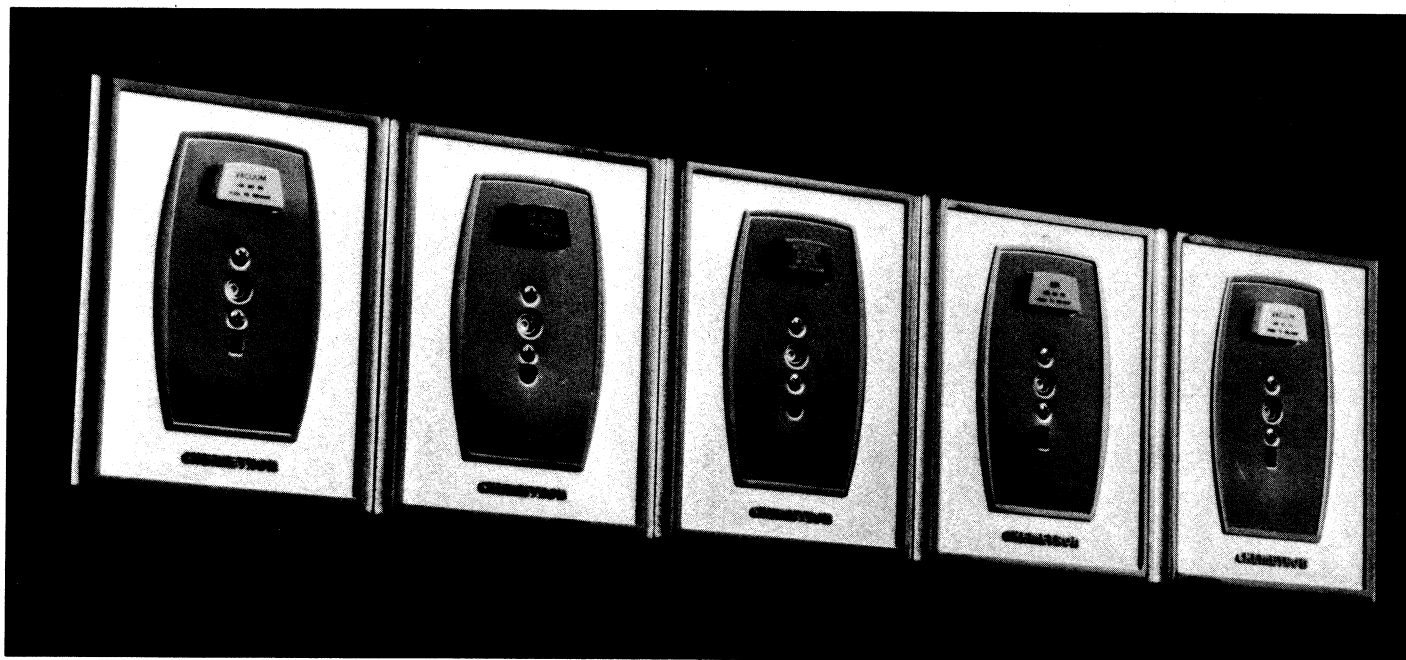

## Table of Contents

Introduction .....	1
General Mechanical Principles .....	2
Materials Of Construction .....	3
Component Parts For Quick Connect And DISS Outlet Stations .....	3
Inspection, Maintenance And Repair Procedures (Quick Connect) .....	4
Inspection, Maintenance And Repair Procedure (DISS) .....	4
Troubleshooting Chart For Quick-Connect Outlet Stations .....	5
Operating Instruction for Chemetron O-Ring Service Tool .....	7
O-Ring Service Replacement Tool Troubleshooting Chart .....	7
Recommendations .....	8
Additional Product Information .....	8

## Introduction

**CHEMETRON MEDICAL GAS OUTLET STATIONS** are designed to provide immediate supply of medical gases and vacuum at such points of use as hospital operating rooms, emergency rooms, intensive care and patient rooms, as well as non-hospital based facilities where a convenient source of medical gases and additional services are needed.

The medical gases include, but are not limited to, oxygen, nitrous oxide, compressed air, nitrogen, carbon dioxide, helium and mixtures of such gases used for medical purposes.

Medical gas pipeline equipment must be kept in dependable operating condition at all times, and demands an effective, conscientiously followed program of periodic inspection, cleaning, maintenance and repair.

For such a program, this manual is a concise, thorough, step-by-step guide for use by responsible maintenance personnel in hospitals or other installations where Chemetron medical gas outlet stations are installed.

**Read this manual thoroughly, and follow it closely at each stage of cleaning, maintenance and repair procedures.**

*It is the responsibility of the user to maintain efficient performance of Chemetron medical gas outlet stations. Allied Healthcare Products, Inc. assumes no liability for accidents or other irregularities arising from failure to observe recommended maintenance procedures or follow cleaning, maintenance and repair practices as presented in this manual.*

*Instructions are applicable to the following series of quick connect outlet stations; 500 and 560 DISS (Diameter Index Safety System) units.*

# General Mechanical Principles

## CHEMETRON OUTLET STATION DESIGN

Chemetron outlets are designed internally and externally to help assure safety and reliability in the delivery of medical gases and vacuum services. A carefully engineered system of safety keying is used between back box, face plate and adapter. An oxygen adapter, for instance, cannot be inserted into a vacuum outlet station. An air face plate cannot be attached to an oxygen back box.

Though not illustrated, the Chemetron DISS\* outlet stations are designed with most of the same features as the Chemetron quick connect outlet stations with the exception of the primary valve body assembly (see component parts p. 3). For example, an installed system of Chemetron (NCG) DISS outlets may be changed to a Chemetron quick connect system by changing the primary valve body assembly and faceplate. This is true for all series Chemetron (NCG) outlets of quick connect or DISS design. For series 238, 248, 148, 236, 246, and 146 outlet stations see Modernization Kits, Form #49-00-0001.

\* Diameter Index Safety System. Ref. Compressed Gas Association, Inc., 1235 Jefferson Davis Highway, Arlington, Virginia 22202, Pamphlet V-5.

## OPERATION

Pressure gas systems are normally designed to deliver 50-55 psig to all station outlets, with the exception of Nitrogen normally being 150-180 psig. Vacuum systems should be maintained at minimum 12-15" Hg at the outlet station farthest away from the vacuum pumps.

When not in use, gas is in a non-flowing state within the outlet station, sealed by O-rings in the poppet (A) and valve body (C). O-ring (B) seals the valve body within the outlet base housing - Figure 2.

Inserting the adapter pushes the poppet inward, permitting gas to flow through the adapter. Leakage is prevented by the O-ring (C) encircling adapter (D) - Figure 1.

When the primary valve body is removed for inspection and servicing, line gas pressure forces the secondary check valve (E) tight against the seat, sealing the gas against loss during the period of maintenance - Figure 3.

*Vacuum outlet stations do not incorporate secondary check valves. A flat object such as a quarter may be used to seal the vacuum flow during service of the primary valve body.*

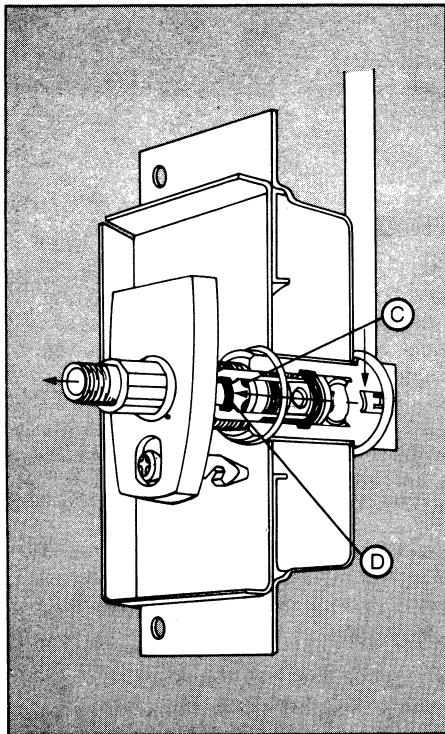

FIGURE 1  
Flow condition.

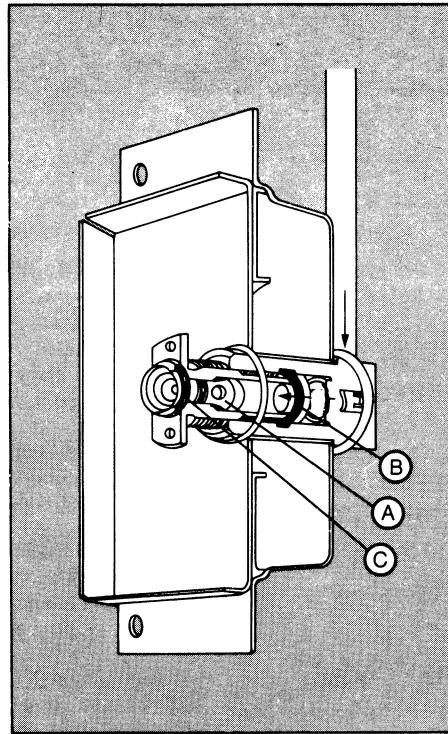

FIGURE 2  
No flow condition.

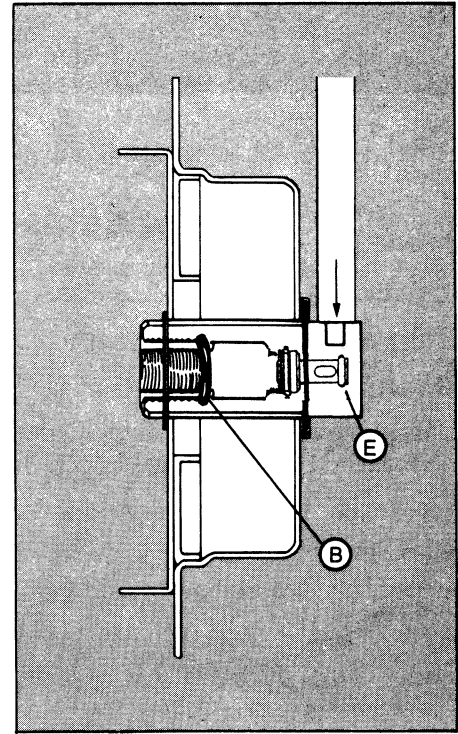

FIGURE 3  
No flow condition under  
maintenance

# Materials of Construction — Quick Connect Model

DESCRIPTION	CATALOG NO.
1. 6" copper tube for connection to medical gas or vacuum supply line.	
2. Swivel base housing.	
3. Back box. (Field replacement of items 1,2 and 3 are not feasible).	
4. Secondary check kit (6 each):	64-90-0650
A. Secondary check assy.	
Spring (for vac.)	
5. Housing base O-ring (12 each).	64-90-0185
6. Poppet.	98-90-0002
7. Poppet O-ring kit (12 each).	64-90-90-0097
8. Valve body assemblies (poppet and O-rings):	
Valve body with poppet-pressure.	64-90-0620
Valve body with poppet-vacuum.	64-90-0621
Valve body kit with poppet-pressure 4 each.	64-90-0653
9. Valve body O-ring kit (12 each).	64-90-0186
10. Face plate assemblies:	
Oxygen	64-91-1501
ISO64-91-1551	
Nitrous Oxide	64-91-1504
Vacuum	64-91-1502
ISO64-91-1552	
Air	64-91-1503
ISO64-91-1553	
Evacuation Vacuum	64-91-1506
CO <sub>2</sub>	64-91-1507
O <sub>2</sub> /CO <sub>2</sub>	64-91-1508
ISO64-91-1558	
11. Latch spring kit (12 each).	64-90-0096
12. Face plate mounting screw kit (48 each).	64-90-0031
13. Vacuum spring kit (6 each).	64-90-0034
14. Test plug kit (12 each).	64-90-0652
15. Back box mounting screw/fastener kit (24 each).	64-90-0652

# Materials of Construction — DISS Model

DESCRIPTION	CATALOG NO.
16. DISS poppet all service except oxygen, vacuum and evac.	64-90-0029
17. DISS poppet oxygen, vacuum and evac.	64-00-0028
18. DISS valve body, key ring and poppet assembly:	
Oxygen	64-90-0631
Nitrous Oxide	64-90-0633
Vacuum	64-90-0632
Air	64-90-0634
Evacuation Vacuum	64-90-0638
N <sub>2</sub>	64-90-0636
CO <sub>2</sub>	64-90-0635
O <sub>2</sub> /CO <sub>2</sub>	64-90-0637
19. DISS Face Plate Assemblies:	
Oxygen	64-90-1561 ISO64-91-1571
Nitrous Oxide	64-91-1564
Vacuum	64-91-1562 ISO64-91-1572
Air	64-91-1563 ISO64-91-1573
Evacuation Vacuum	64-91-1566
N <sub>2</sub>	64-91-1565
CO <sub>2</sub>	64-91-1567
O <sub>2</sub> /CO <sub>2</sub>	64-91-1568 ISO64-91-1578
20. DISS face plate screw kit (24 each).	64-90-0030
21. DISS dust cap and chain assembly:	
Oxygen	64-90-0098
Nitrous Oxide	64-90-0100
Vacuum	64-90-0099
Air	64-90-0101
22. DISS poppet O-ring only.	34-90-0026

## Back Box Assembly (Quick-Connect & D.I.S.S) Quick-Connect

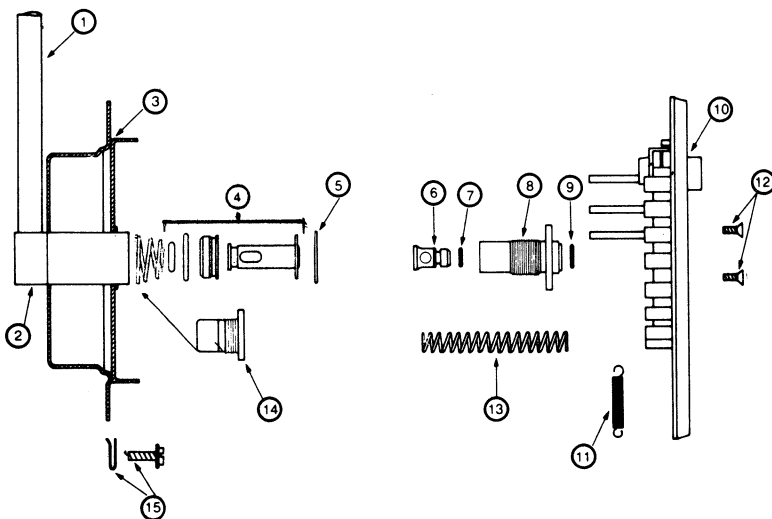

## D.I.S.S.

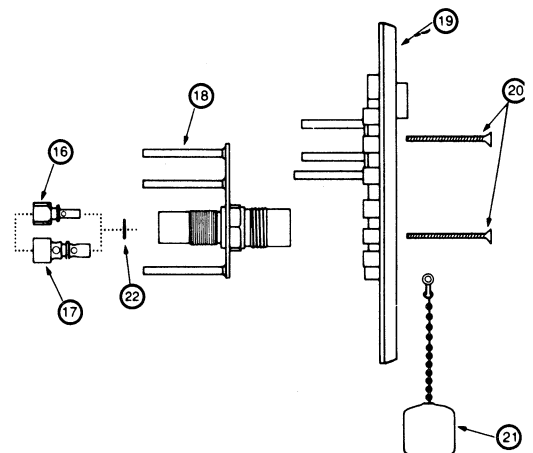

# Inspection Maintenance and Repair Procedures for Chemetron Quick-Connect Outlet Stations

Following is a step-by-step method of inspection, maintenance and repair for the Chemetron medical gas outlet station, series 500, 400, 378, 349 and 348 quick-connect units. The purpose is to determine if parts are broken, missing, worn, distorted or contaminated, or if the unit is malfunctioning from any other possible causes. **This program should be followed at intervals of not more than six months and more often in areas of greater use, such as operating rooms and intensive care units.**

## PERIODIC INSPECTION

1. Clean all the exposed parts. **WARNING: DO NOT USE OIL OR GREASE ON OR NEAR OUTLETS.** Clean face plates and other exposed areas with a cloth dampened with water and/or common hospital disinfectants.
1. Nettoyer toutes les pièces exposées. **MISE EN GARDE: NE PAS UTILISER D'HUILE OU DE GRAISSE SUR OU À PROXIMITÉ DES SORTIES.** Nettoyer les plaques avant et les autres surfaces exposées à l'aide de chiffons humectés d'eau et/ou de désinfectants normalement employés dans les hôpitaux.
2. Insert the adapter (figure 2, page 3) into the face plate. Unlatch it and withdraw several times to determine if it is binding, or if looseness or other malfunction is present. See the trouble-shooting chart (page 5) for possible causes of malfunction, and for methods of correction.

## DISASSEMBLY

3. Remove the two Phillips head face plate screws (item 12) and take off the face plate.
4. Examine the face plate latch springs (item 11) and replace them if loose.
5. Examine the face plate (item 10) and replace it if bent or distorted.
6. Remove the valve body (item 8) by turning it counterclockwise until it is separated from the housing. When the valve body is removed from pressure gas services, the secondary check valve assembly (item 4A) is released, and line pressure forces the secondary check valve (item 4A) against the seat. This seals gas or air from escaping during inspection and maintenance. Inspect the secondary check valve (item 4A) for proper seating. If the seating is incomplete follow instructions in note 10. (See figure 3.) Examine valve body (item 8) for signs of distortion or wear at the entry port or for worn uneven screw threads. Replace if necessary, otherwise replace the valve body O-ring (item 9) using the O-ring which has been lubricated lightly with Chemetron O-ring lubricant (part no. 64-90-2111).
7. Remove the poppet (item 6) and examine it for wear, distortion or contamination. Replace it if necessary. Otherwise, replace the Poppet O-ring (item 7), first lubricating it lightly with Chemetron O-ring lubricant (Part # 64-90-2111).

8. Insert vacuum spring (item 13) and replace if necessary. Set aside until reassembly.
9. Remove and replace the housing O-ring (item 5), lubricating lightly as indicated above.
10. Remove the secondary check valve (item 4A) with insertion tool, (part no. 64-90-2050). (See figure 3). **WARNING: BEFORE REMOVING SECONDARY VALVE, SHUT OFF THE GAS FLOW, SERVING THE OUTLET STATION, AT THE NEAREST ZONE VALVE BOX. BE SURE TO CHECK WITH OTHER DEPARTMENTS ON THE SUPPLY LINE, SO THAT IN SERVICE OPERATIONS ARE NOT INTERRUPTED.**  
**MISE EN GARDE: AVANT D'ENLEVER LE BOÎTIER, COUPER L'ÉCULEMENT DE GAZ POUR LE SERVICE À LA SOUPAPE DE LA ZONE LA PLUS PROCHE. S'ASSURER DE VERIFIER AVEC LES AUTRES DÉPARTMENTS SUR LA LIGNE D'ALIMENTATION DE MANIÈRE À CE QUE LES OPERATIONS EN SERVICE NE SOIENT PAS INTÉRROMPUES.**
11. Examine the secondary check valve assembly (item 4A). Replace if necessary. Lightly lubricate the replacement O-rings before assembly, with 64-90-2111 lubricant.
12. Reinstall the secondary check valve assembly into the block with the large end facing out using the insertion tool (part no. 64-90-2050). (See Figure 3).
13. Reassemble all the components in reverse order of disassembly. Make sure the O-rings are seating, and the unit is satisfactorily assembled at each stage. When reinstalling the valve body, turn the body past the housing O-ring (item 5), rather than pushing it, to assure that the O-ring is not unseated. Turn the valve body clockwise into the housing until the valve body flanges are even with the finished wall. The valve body may be turned outward to compensate for up to 3/8" variation in the wall thickness.
14. If gas or other service has been turned off, be sure it is restored after the unit has been serviced. **CAUTION: Before putting the system back into service, the flow of gas from each outlet station for oxygen, mixed gases containing oxygen and compressed air should be tested with an oxygen analyzer per NFPA 56F.**  
**ATTENTION: avant de remettre le système en service, l'écoulement de gaz à partir de la station de chaque sortie pour oxygène, gaz mixtes contenant oxygène et air comprimé, doit être vérifié avec un analyseur d'oxygène conformément à NFPA 99. paragraphes 542 et 543.**

# Inspection Maintenance and Repair Procedures for Chemetron DISS Outlet Stations

Following is a step-by-step method of inspection, maintenance and repair for the Chemetron medical gas outlet station, series 560 DISS unit.

## PERIODIC INSPECTION (Reference page 3)

1. Clean all the exposed parts. **WARNING: DO NOT USE OIL OR GREASE ON OR NEAR OUTLETS.** Clean face plates and other exposed areas with a cloth dampened with water and/or common hospital disinfectants.
1. Nettoyer toutes les pièces exposées. **MISE EN GARDE: NE PAS UTILISER D'HUILE OU DE GRAISSE SUR OU À PROXIMITÉ DES SORTIES.** Nettoyer les plaques avant et les autres surfaces exposées à l'aide de chiffons humectés d'eau et/ou de désinfectants normalement employés dans les hôpitaux.

2. Using a female DISS adapter for the medical gas outlet being inspected, determine the proper mating of the threads. Be certain the female DISS adapter nipple contains an O-ring that is in good repair. Female adapters for pressure gases should be connected to a device containing a shut-off valve to avoid uncontrolled gas flow from the outlet.
3. Audibly test for leakage around the mated threads.
4. Visually inspect the male threads of the station outlet without the female adapter to determine that no threads are crossed, worn, distorted, discolored, or otherwise indicating needed replacement of the valve body.(item 18).

## DISASSEMBLY (Reference page 3)

5. Remove the two oval head face plate screws (item 20) and take off the face plate.
6. Examine the face plate and replace it if bent or distorted.
7. Remove the valve body (item 18) by turning it counter-clockwise until it is separated from the housing. When the valve body is removed, a secondary check valve will seal air or gas against escaping. Examine the valve body for worn or defective threads, and replace it if necessary. Remove the poppet (items 16 or 17) and examine for wear, distortion or contamination. Replace them if necessary. Otherwise, replace the poppet O-ring (item 23) lubricating it lightly with Chemetron O-ring lubricant. (Part #64-90-2111)

(For balance of disassembly and repair, follow procedures as explained for quick-connect units, steps 8 through 14).

### **CHEMETRON medical gas outlet stations should be checked thoroughly after:**

- Initial installation is complete.
- Medical gas and vacuum lines are extended or otherwise altered.
- Major overhaul is performed in the general area of medical services and supply.
- Time prescribed by local or national standards and codes. Refer to NFPA 56F and/or CSA Z305.1 standards for non-flammable medical gas systems.

# Chemetron Quick Connect Outlet Stations Series 500

## Troubleshooting Chart

SYMPTOM	POSSIBLE CAUSE	CORRECTIVE ACTION
Difficult to insert/extract adapter.	Using incorrect gas service adapter.	Check for correct gas service adapter.
	Valve body O-ring is dried out or defective.	Lubricate the O-ring, part #64-90-0186, with Chemetron O-ring lubricant, catalog #64-90-2111 or replace the O-ring. See also the "O-ring service tool section", catalog #64-90-2060, page 7.
	The face plate or latch is binding, bent or damaged.	Remove the face plate and adjust the valve body flush with the wall surface, then replace face plate.
Leakage with the adapter inserted.	Failure or inability to release latch.	Push the latch button in; or apply a slight inward pressure on the adapter before depressing the latch button.
	Faulty primary valve body O-ring.	Replace the O-ring, part #64-90-0186. See also "O-ring service tool section," catalog #64-90-2060, page 7.
Leakage without the adapter inserted.	The primary valve body is worn or distorted.	Replace the O-ring primary valve body, see item 8, page 3.
	Failure of poppet O-ring to seal.	Replace the O-ring, part #64-90-0097, item 7, page 3.
Leakage around the valve body.	The poppet is worn or distorted.	Replace the poppet, part #98-90-0002 item 6, page 3.
	Failure of base housing O-ring to seal.	Lubricate or replace the O-ring, part #64-90-0185, item 5, page 3.
Reduced flow.	Foreign matter is lodged in the outlet station (e.g., scale from brazing, suctioned material, etc.)	Disassemble, clean* and/or blow clear. <b>CAUTION: USE PROTECTIVE EYEWEAR WHEN PURGING ANY PRESSURE SERVICE.</b>
	The face plate screws are loose.	Tighten the face plate screws.
	The valve body is not installed flush to the cover plate.	Remove the face plate and adjust the valve body, item 8, page 3, outward until it is flush with the face plate.

\* When cleaning metal parts, adhere to NFPA 56F, chapter 5, para 511, "The use of organic solvents, for example, carbon tetrachloride, is prohibited."

# Chemetron O-Ring Service Tool

## Figure 1 — Initial Setting

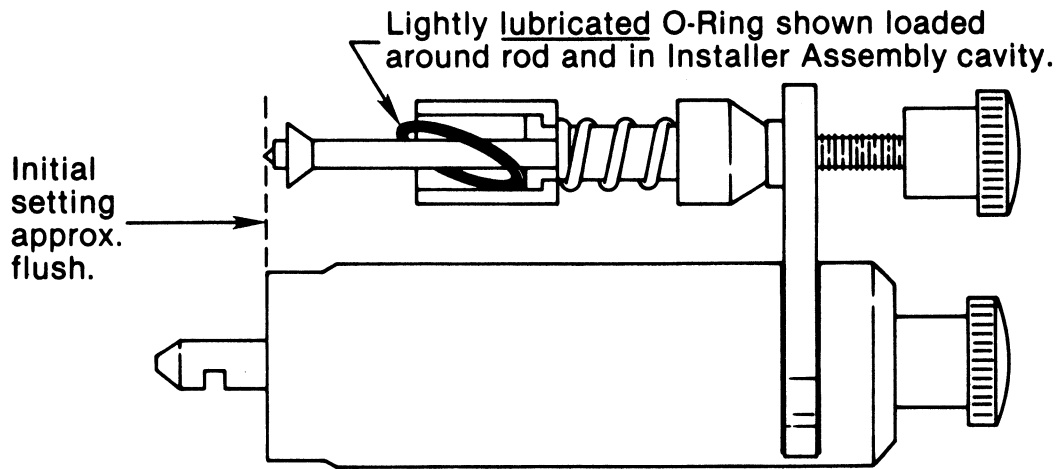

## Figure 2 — Operation

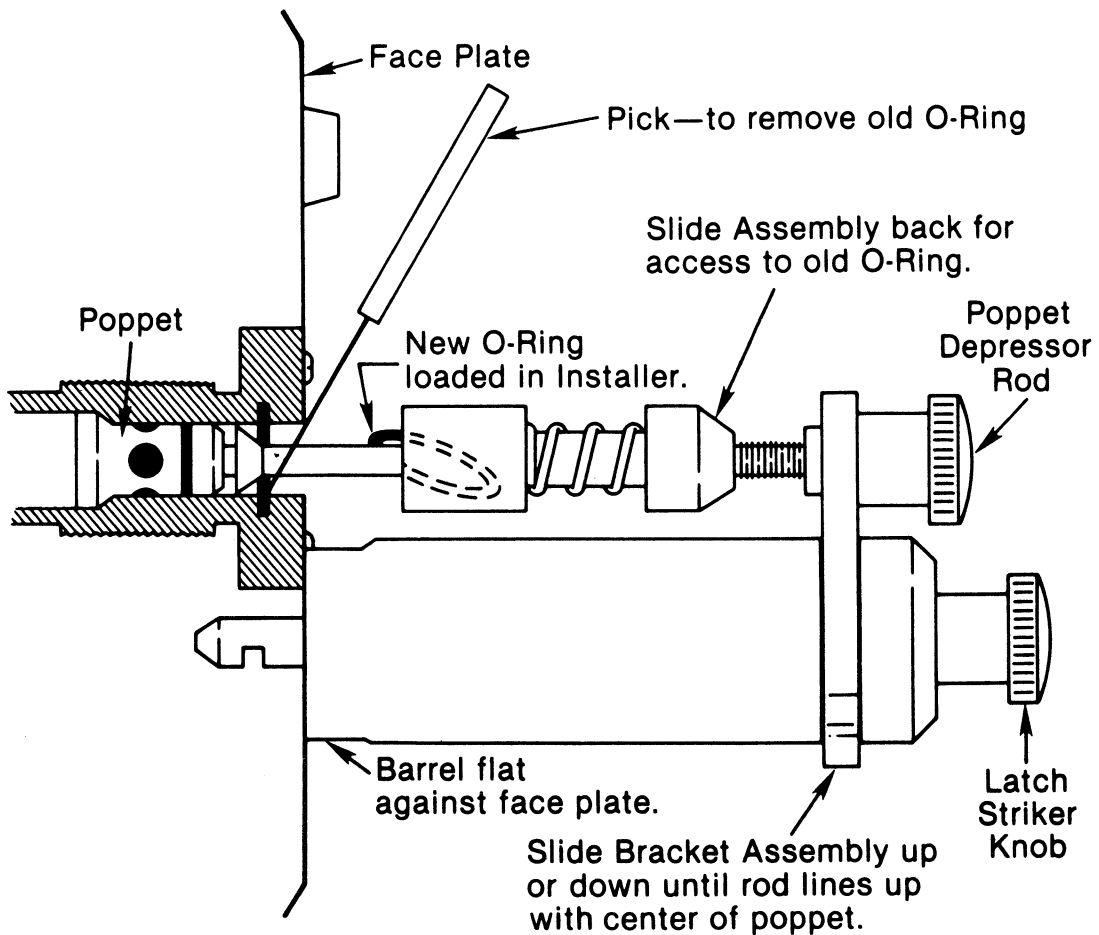

# Operating Instruction For The Chemetron O-Ring Service Tool

The Chemetron outlet station O-ring service tool aids in rapid removal and replacement of the valve body O-ring (item 9) without disassembly or removal of the face plate. The Chemetron O-ring service tool can be used on Chemetron/NCG quick-connect outlet station series 238, 248, 148, 348, 349, 378, 400 and 500 for oxygen, compressed air, vacuum, nitrous oxide and carbon dioxide service.

The O-ring service tool is attached to the outlet station latch mechanism which holds the tool in place. A poppet depressor rod pushes the poppet back and exposes the valve body O-ring without allowing gas to flow. After removal of the old O-ring, a push of the O-ring installer containing a new O-ring seats the replacement O-ring. Following is a step by step procedure for using the Chemetron O-ring service tool.

## VALVE BODY O-RING (ITEM 9) REPLACEMENT

1. Holding the O-ring service tool in one hand, adjust the poppet depressor rod until the forward tip is even with the forward edge of the black barrel. (See figure 1, opposite page.)

Lubricate, very lightly, one O-ring (Catalog No. 64-90-0186) using Chemetron medical gas outlet O-ring lubricant (Catalog No. 64-90-2111) and insert the O-ring in the installer assembly. (See figure 1, opposite page.)

2. Insert the tool in the outlet station latch opening. (See figure 2, opposite page.) If it does not catch, adjust the latch striker knob counter-clockwise and insert again. Turn the latch striker knob clockwise until the tool is held snug against the

face plate. **CAUTION: DO NOT OVER-TIGHTEN OR DAMAGE TO THE LATCH MECHANISM COULD RESULT.**

3. Center the rod tip on the poppet by moving the rod bracket up or down. Turn the poppet depressor rod knob clockwise. This advances the rod toward the poppet.
4. Advance the poppet depressor rod until the old O-ring is exposed. (Approximately 7 turns clockwise, See Figure 2, opposite page.) The large edge of the cone on the depressor rod should be just beyond the O-ring groove. You should not hear or feel gas flowing. If you do, you have depressed the poppet too far.
5. Using the O-ring pick (Catalog No. 64-90-2072), extract the old O-ring. Cut or snip the extracted O-ring away from the rod. Inspect the O-ring groove and be certain it is clear of debris or foreign material.
6. Slide the O-ring installer forward. Holding the rear portion of the installer (behind the spring), push forward until the installer spring is compressed. Pull the installer back.
7. If, by visual examination, the O-ring is not properly seated, repeat step number 6 a few times in rapid succession.
8. After the O-ring is properly seated, the tool may be removed by first, retracting the poppet depressor, then loosening the lower latch knob (turn counterclockwise) and releasing the outlet latch mechanism. The poppet should return to the normally closed position.

## O-Ring Service Tool Troubleshooting Chart

### PROBLEM

1. The O-ring partially seats, it is difficult to compress the installer.
2. The O-ring knots or comes back out, it is difficult to compress the installer.
3. The O-ring twists or appears seated but comes back out when the installer compresses normally.
4. The tool fails to latch or remain latched.

### POSSIBLE REASON

1. The poppet was depressed insufficiently, or the difficulty was caused by failure to lubricate the O-ring.
2. The poppet was depressed insufficiently, or the difficulty was caused by failure to lubricate the O-ring.
3. The poppet was depressed too far.
4. The outlet latch is probably worn or distorted. (See "recommendations section", page 8, for older outlets).

(FIGURE #3)

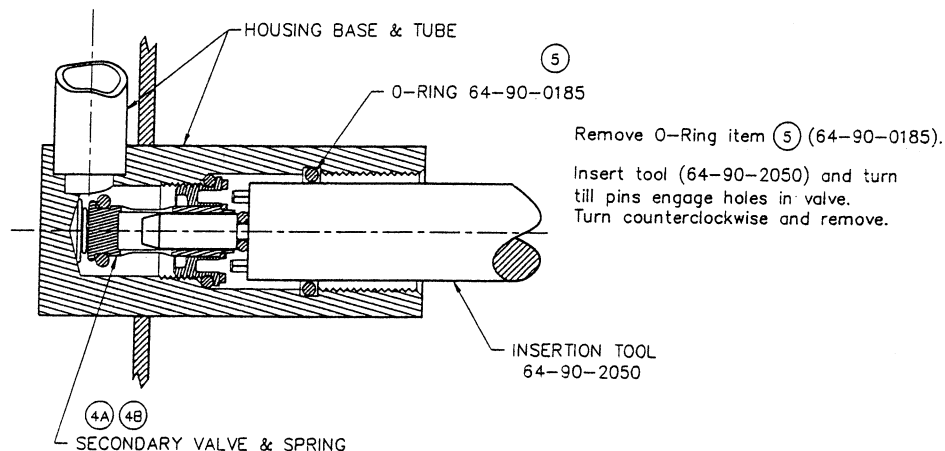

# Recommendations

## Series 238, 248, and 148 quick connect outlet stations series 236, 246, and 146 diss outlet stations

See **modernization kits, form # 49-00-0001**. The Chemetron Medical division urges the installation of modernization kits in all of the outlet station series indicated on previous page. The benefits of modernizing are:

- **Improved appearance.**
- **Current production latching mechanisms.**
- **Readily available repair parts.**
- **Compliance with NFPA 56F, and CSA Z305.1, requirements.**

## Additional Product Information

FORM NO.	DESCRIPTION
10-00-0001	Chemetron medical gas piping systems.
64-00-2000	Replacement parts for Chemetron (NCG) quick-connect medical gas outlets.
64-00-2001	Replacement parts for Chemetron (NCG) DISS medical gas outlets.
64-00-2006	Medical gas outlet stations 400/460 series operation, maintenance and repair instructions.
49-00-0001	Modernization kits.
64-00-2005	Chemetron medical gas outlet repair kit.
11-00-0001	Adapters/couplers/fittings.
11-00-2000	Vacuum bottle holder adapters and/or couplers parts list.

## ***Allied Healthcare Products, Inc.***

### ***CHEMETRON Medical Division***

1720 Sublette Avenue  
St. Louis, MO 63110  
Telephone: (314) 771-2400  
Toll Free: (800) 444-3954

### ***INSTRUMENTS OF CARE***

The seller makes no warranties, express or implied, including, but not limited to, the implied warranties of merchantability and fitness for a particular purpose, except as expressly stated in seller's sales contract or sales acknowledgement form.