



BELMED INC.

MANIFOLD SYSTEMS

WITH CROSSGUARD safety system

INSTALLATION AND INSTRUCTION MANUAL

DESCRIPTION

INSTALLATION

OPERATION

SERVICE

DESCRIPTION

The National Fire Protection Association Standard, NFPA 56F-1977 for Non-Flammable Medical Gas Systems, Chapter 6, applies to small supply systems in non-hospital based facilities. Small systems are those in which the medical gas is a cylinder system which supplies no more than ten use points, and has no more than 2000 cubic feet of gas in facility.

The Beimed Gas Supply Systems conform with the code requirements specified in NFPA No. 56F-1977, Chapter 6, and include the following code required features:

1. Pressure regulator set at 50-55 PSI installed on each cylinder
2. Flexible hose of 1000 PSI burst strength
3. Connections between regulator and piping system are approved Diameter Index Safety System (DISS)
4. Check valve located down stream of each regulator
5. Pressure relief valve for each gas pipeline, set at 70-80 PSI, located downstream of each check valve
6. Restrainers to adequately secure cylinders from tipping
7. Audible and visual alarm for each gas pipeline, activated by an automatic pressure switch when pipeline pressure is less than 50 PSI or more than 65 PSI.

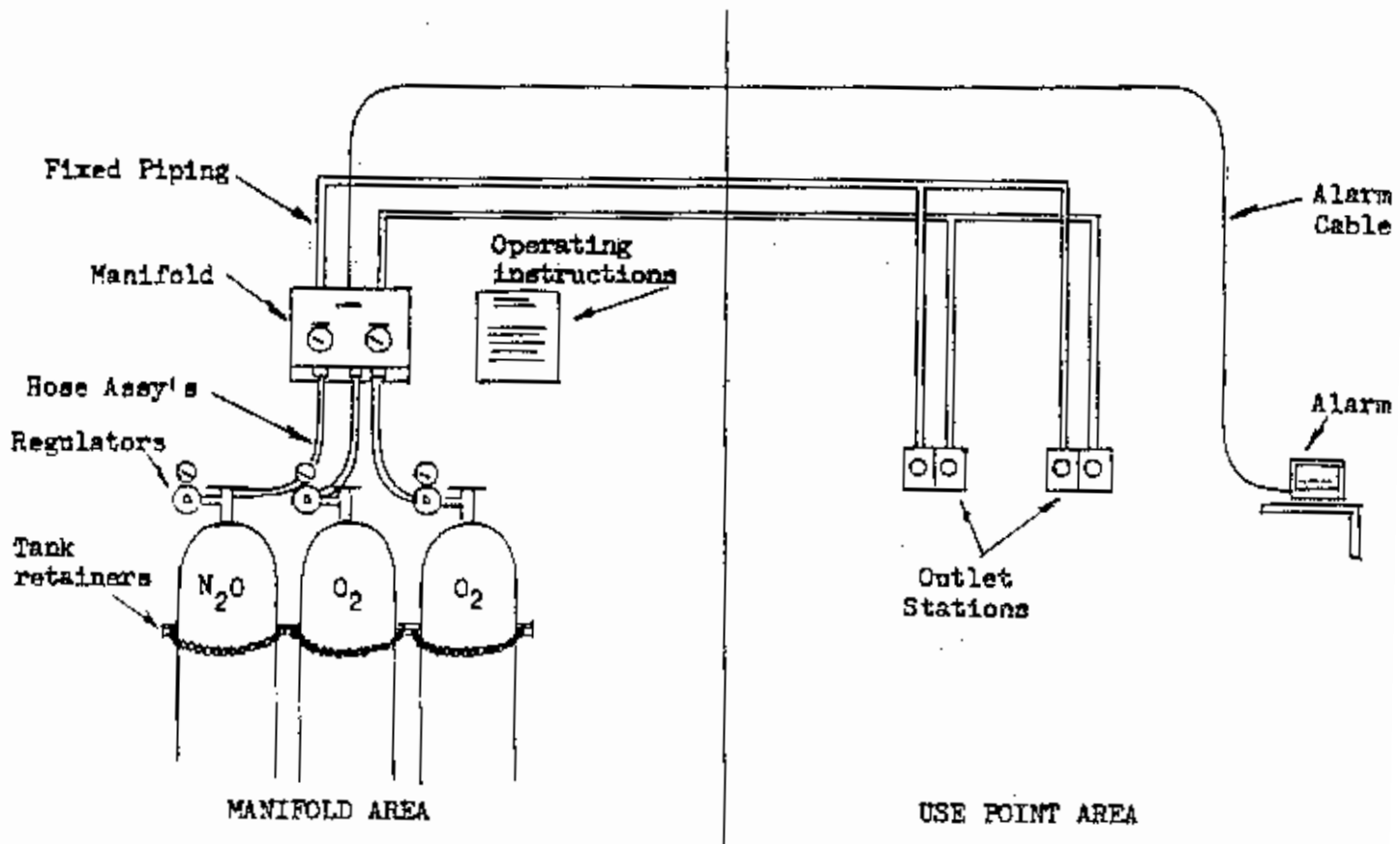

Figure 1, TYPICAL MANIFOLD SYSTEM

NFPA REQUIREMENTS

This instruction manual covers installation instructions for this equipment only. The following information is intended to provide a general guideline. NFPA No. 56F-1977, Chapter 6, should be consulted for detailed information. Reprints are available by writing to: The National Fire Protection Association, 470 Atlantic Ave., Boston, Massachusetts 02210.

TANK ROOM

1. No more than 2000 cubic feet of gas in building
2. Gas stored in locked cabinet or room
3. Room or cabinet to have 1 1/2 hour fire rating
4. At least 72 square inches of vent area
5. Cylinders securely restrained to wall
6. No compressors, flammable material or other equipment in cylinder room
7. No smoking in cylinder enclosure

PIPING

8. Pre-cleaned, degreased, and capped type L or K tubing ONLY
9. Solder connections should be of 1000^o F. silver solder
10. DO NOT use oil or grease on any part of system
11. Concealed piping should conform to local codes
12. Pipeline marked every 20 feet with gas content
13. No more than 10 outlet stations of the approved type per facility
14. Supply line shut off valves should be installed inside facility when cylinder site is remote from facility (i.e. outside, basement, etc.)
15. Threaded connections for valves, etc. should be tinned with soft copper, or an approved type sealing compound

TESTING

PRESSURE TEST: After installation, each pipeline system must be tested for leakage using dry nitrogen at 150 PSI for 24 hours. Each joint should be checked with soapy water or an approved type leak detector.

CROSSLINE TEST: Each gas pipeline MUST be checked to determine that no cross connections have been made. Reduce pipeline pressure to zero and then pressurize one pipeline to 50 PSI using gas intended for that pipeline. Check each outlet station to determine that gas being dispensed only from pipeline being tested.

TEST PROCEDURES MUST BE PERFORMED AND ARE VITAL FOR THE SAFE OPERATION OF SYSTEM AS WELL AS YOUR OWN PROTECTION

NOTE: The Belmed Manifold is designed to accept the 24 hr./150 psi pressure test. Relief valve plugs are supplied with each manifold. Plugs are attached to chain and tag, do not disassemble. To plug relief valves, screw plugs into the ends of both relief valve. DO NOT OVERTIGHTEN, a gentle finger tightening is sufficient to prevent valve seat from lifting during test. REMOVE PLUGS AFTER TEST.

INSTALLATION

The Belmed Manifold is designed to be installed with fixed piping exposed or concealed, depending on wall construction. Manifold attaches to wall with three (3) #10 fasteners.

PIPING

Belmed Manifold systems utilize CROSSGUARD SAFETY SYSTEM which is designed to prevent cross-connections between nitrous oxide and oxygen by eliminating common sizes. The Belmed Manifold is supplied with 3/8" O.D. tubing pipeline connector for nitrous oxide and 1/2" O.D. tubing pipeline connector for oxygen. The pipeline connectors attach to manifold with DISS nuts (see figure 2). THE EMPLOYMENT OF THIS DIAMETER INDEXED COPPER TUBING MUST BE INSTALLED THROUGH-OUT ENTIRE PIPING SYSTEM. OUTLET STATIONS MUST BE BELMED OR INCORPORATE THE SAME DIAMETER INDEXING.

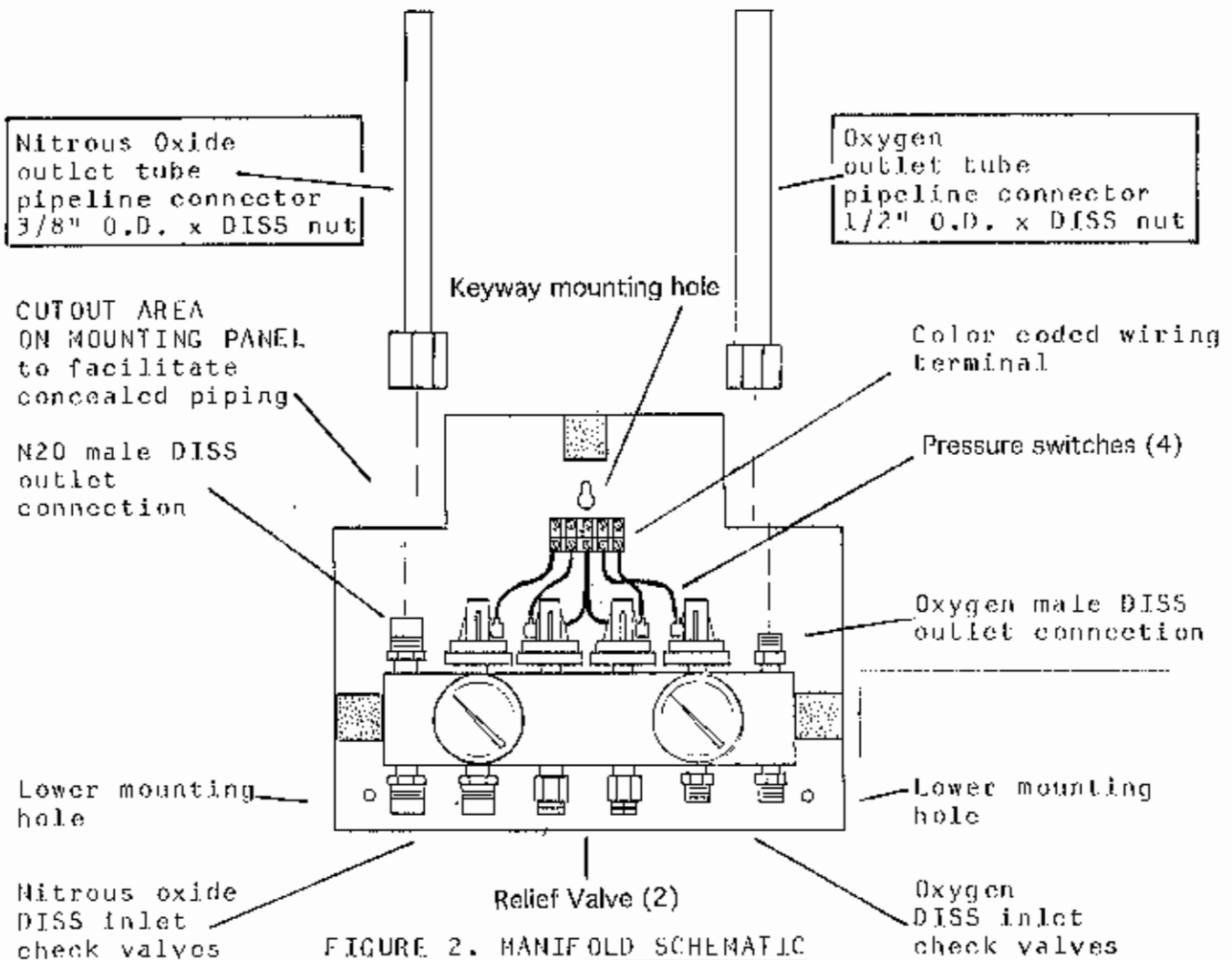

CAUTION

THIS DEVICE CONTAINS CROSSGUARD SAFETY SYSTEM

Utilizing diameter indexed copper tubing. Reducing pipe sizes or tampering with the CROSSGUARD SAFETY SYSTEM constitutes acceptance of liability by the installer. Refer to instructions. Contact Belmed Inc., with any questions or problems.

MANIFOLD

Manifold cover attaches via tongue and groove arrangement. To attach align cover over gauges and push down to remove cover, place thumbs on inside each cover side and push outward slightly while lifting.

Manifold should be installed so that bottom edge is five (5) feet above floor line. Determine center of wall where manifold is to be attached and measure 67 $\frac{1}{2}$ " from floor to this point. Secure a #10 fastener at this point and allow head of fastener to protrude 3/8" from wall. Hang manifold onto fastener through keyway mounting hole. Using manifold as a template, level and mark two lower mounting holes. If piping is to be concealed, also mark for two holes on 8 $\frac{1}{8}$ " centerline in cutout area of mounting panel. Remove manifold and complete all hole drilling.

EXPOSED PIPING INSTALLATION:

Secure manifold to wall as described in previous paragraph. Remove dust covers from DISS male outlet connectors and moderately tighten pipeline connectors to manifold. Couple each pipeline connector to fixed piping and silver solder. Refer to figure #3. NOTE: Do not allow dust or other debris to enter manifold block.

CONCEALED PIPING INSTALLATION:

Drill 2" diameter holes on 8 $\frac{1}{8}$ " centerlines at points marked earlier (paragraph #1) for concealed piping. Cut pipeline connectors 1" above DISS nuts and elbow connectors to suitable lengths of piping and silver solder fittings/piping. (Refer to figure #3). Allow vertical riser lines to hang loosely for later manifold attachment. Note: Do not allow dust or debris to enter manifold block.

ROUGHED IN PIPING INSTALLATION:

If studs are in place but walls not erected, install pipelines as previously described (for either concealed or exposed piping). The bottom edge of DISS nuts on pipeline connectors should be 64 $\frac{1}{2}$ " above floor line and risers on 8 $\frac{1}{8}$ " centerlines for later manifold attachment. Allow vertical risers to hang loosely to provide some play in lines to attach DISS fitting to manifold. PROVIDE INFORMATION FOR DRYWALL INSTALLER WITH HOLE DIMENSIONS. (TWO - 2" DIA. HOLES, 68 $\frac{1}{4}$ " ABOVE FLOOR, 8 $\frac{1}{8}$ " CENTERS).

COMPLETE REST OF PIPELINE INSTALLATION, WHEN COMPLETELY INSTALLED, PERFORM REQUIRED PRESSURE TEST AND CROSS LINE CHECK (see page #2) PURGE PIPELINE SYSTEM WITH INTENDED GAS.

CYLINDER RESTRAINT INSTALLATION: Securely anchor screw eyes into wall studs 40" above floor line. Allow minimum of 10" for each cylinder. Generally, 32" apart for 3 cylinders and 48" apart for 4 cylinders to match wall stud on 16" centers. Attach hooks of restraining belt into screw eyes. Pull belt through cambuckle until taut around cylinders. Secure belt end through loop. To remove restraint, press the thumb release on cambuckle. Restraint will adapt to many other cylinder configurations. Always securely anchor 40" above floor line.

CONNECT REGULATORS AND HOSES (SEE PAGE #9 for regulator adjustment)

FIGURE 3. MANIFOLD INSTALLATION

CONCEALED PIPING INSTALLATION

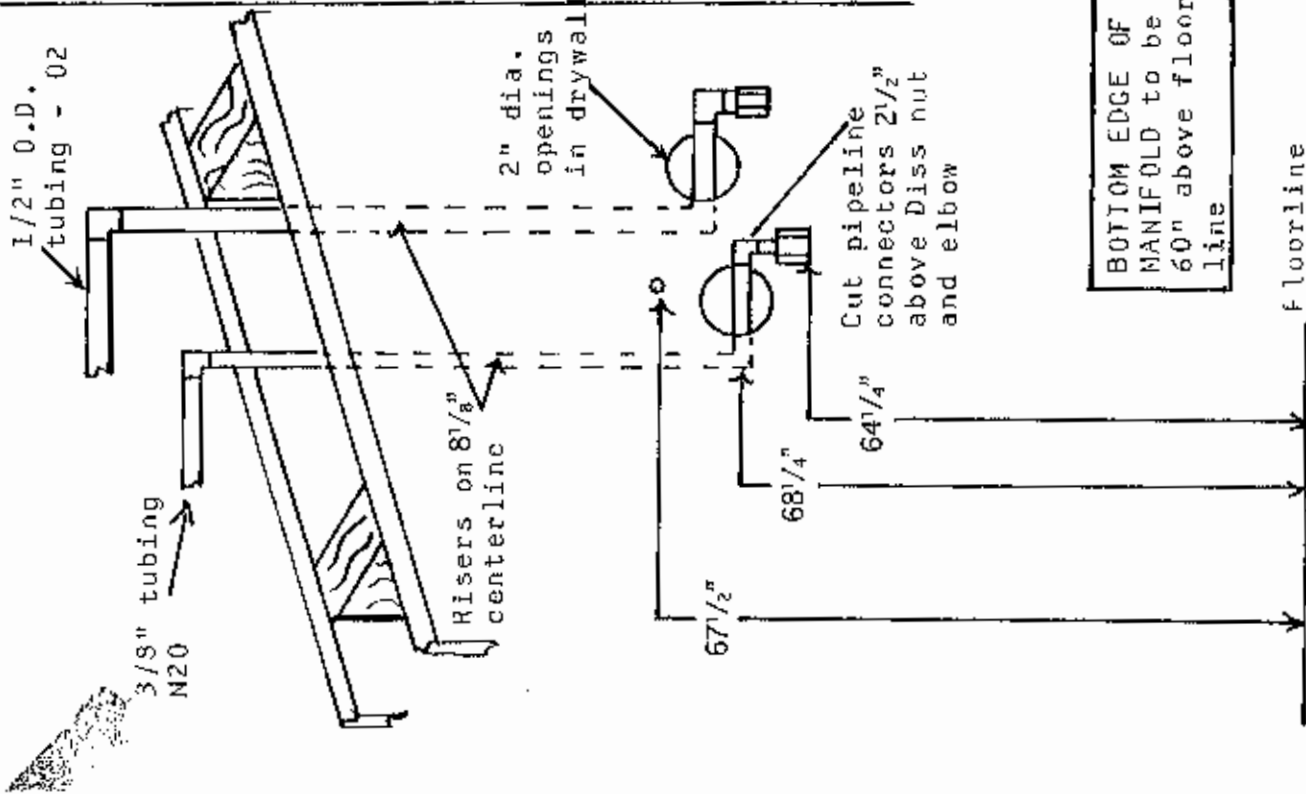

EXPOSED PIPING INSTALLATION

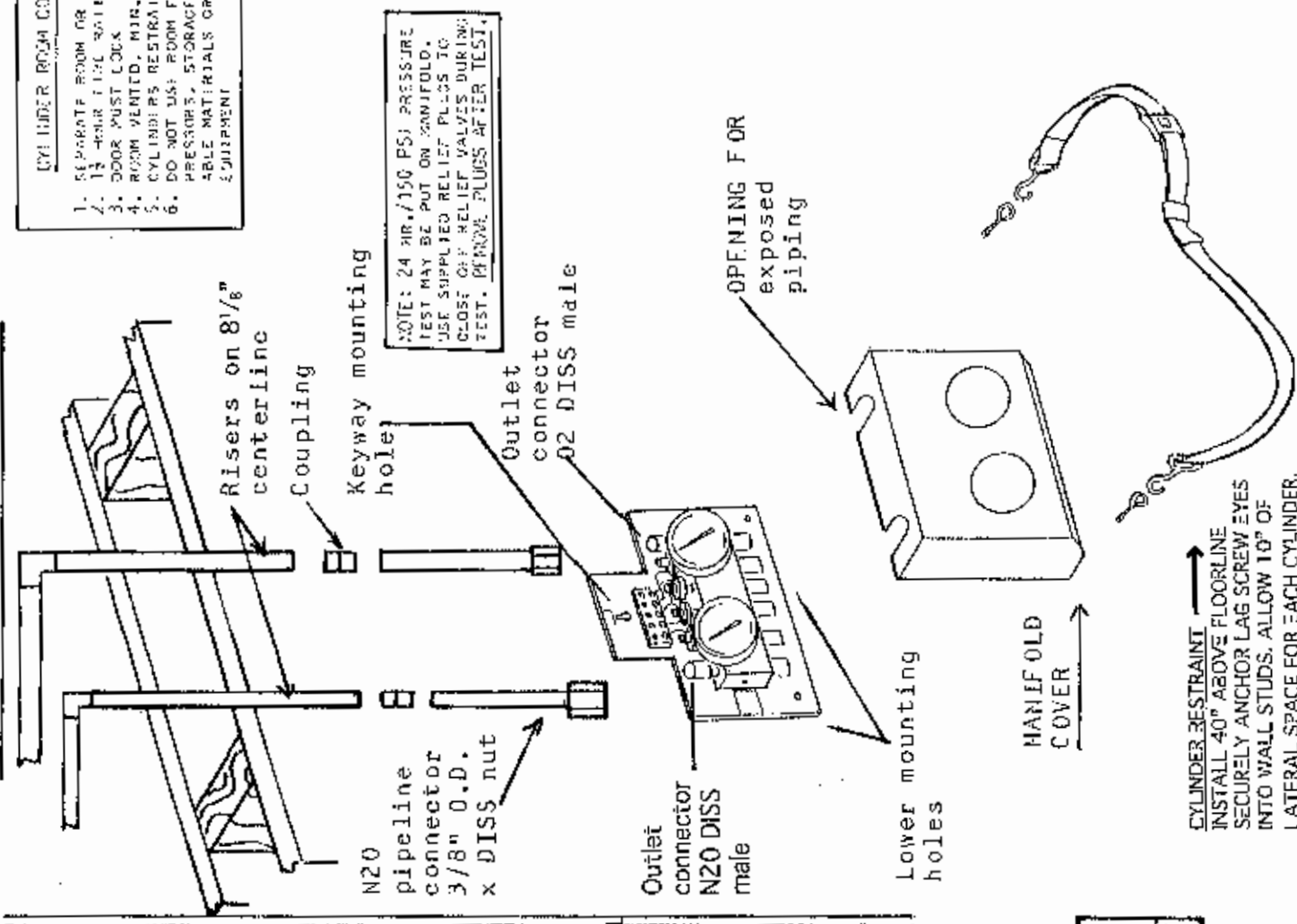

CYLINDER ROOM CONSTRUCTION

1. SEPARATE ROOM OR CABINET
2. 1 1/2 HOUR FIRE RATING
3. DOOR MUST LOCK
4. ROOM VENTED. MIN. 72 SQ. IN.
5. CYLINDERS RESTRAINED
6. DO NOT USE ROOM FOR COM- PRESSORS, STORAGE OF FLAM- MABLE MATERIALS OR OTHER EQUIPMENT

MANIFOLD

WALL TYPE ALARM INSTALLATION

- 5 CONDUCTOR CABLE, ROUTE TO MANIFOLD
- 3 GANG ELEC. BOX W/CLAMPS & MOUNTING BRACKET, MOUNT TO BE FLUSH WITH FINISHED WALL, HGT. IS 5 FT. ABOVE FLOOR LINE. MAY ALSO BE MOUNTED IN SOME EXISTING WALLS. SEE PAGE #7.
- 2 CONDUCTOR CABLE, ROUTE TO TRANSFORMER

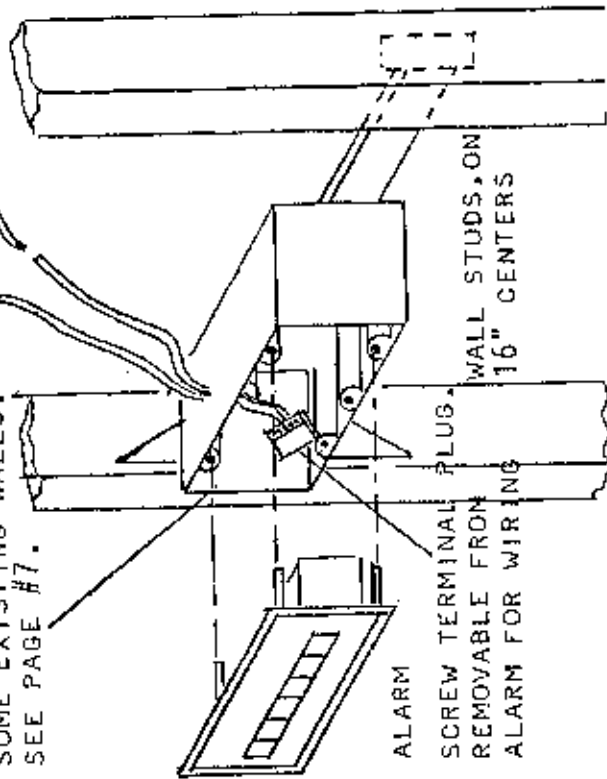

WIRING CONNECTION TO ALARM

REMOVABLE TERMINAL PLUG IS LOCATED ON REAR OF ALARM. PULL TO RIGHT TO REMOVE FROM SOCKET. ATTACH WIRES FROM MANIFOLD & TRANSFORMER TO PROPER SCREW TERMINALS OF PLUG AND RECONNECT TO ALARM SOCKET. TERMINAL NOS. : #1-02 HI (red) #2-02 LO (green) #3-COM (black) #4-02 LO (white) #5-020 HI (brown) #6 & #7-120V TRANSFORMER WIRES

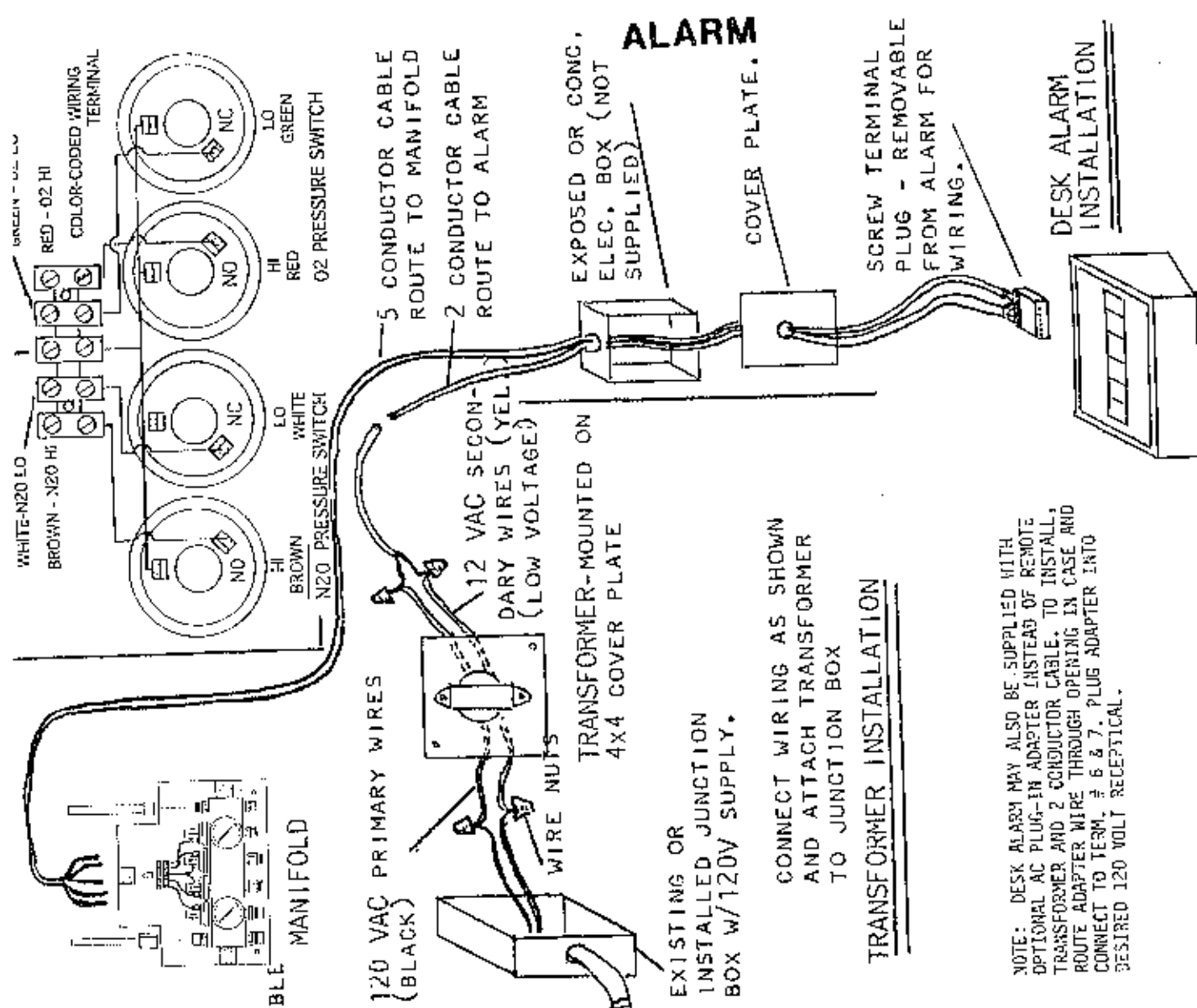

NOTE: DESK ALARM MAY ALSO BE SUPPLIED WITH OPTIONAL AC PLUG-IN ADAPTER INSTEAD OF REMOTE TRANSFORMER AND 2 CONDUCTOR CABLE. TO INSTALL, ROUTE ADAPTER WIRE THROUGH OPENING IN CASE AND CONNECT TO TERM. # 6 & 7. PLUG ADAPTER INTO DESIRED 120 VOLT RECEPTICAL.

ALARM

DESK STYLE ALARM INSTALLATION

Route manifold & transformer cables as shown on page 6. (elec. box not supplied) Remove alarm from case by gently pulling up on bezel while holding case. Remove terminal plug from alarm and wire per page 6. To replace alarm align pins on alarm with holes in case and push down. Special Note: desk alarm may be supplied with plug in type AC adapter instead of remote transformer. To install AC plug in adapter, attach adapter wires to terminals #6 and 7 of alarm and plug into nearest receptical. Test Alarm.

WALL STYLE ALARM INSTALLATION

Attach 3-gang electrical box to studs at a point 5 ft. above floor line. (studs must be in 16" centers) Gang box has mounting bracket and clamp for easy attachment to studs (nail to wood studs, sheet metal screw to aluminum studs) Gang box must be mounted level and installed to insure alarm will be flush to finished wall surface. Depth gage markings are located on side of box for 3/8", 1/2" and 5/8" wall thickness. We recommend gang box be installed slightly below flush to finished wall (approx. 1/8") to insure alarm will fit snug and flush with finished wall surface. Route manifold and transformer cables through gang box, remove approximately 6" of cable cover from wiring and strip about 1/2" from each wire end. Clamp cable to gang box with clamp inside box. (Clamp may have to be moved) To attach wires to alarm, remove terminal plug from alarm and attach stripped wire ends to proper terminal (see page 6) Reconnect plug to alarm, align pins on alarm with holes in gang box and slide alarm into gang box until alarm is flush with wall surface. Test alarm.

EXISTING WALL INSTALLATION

Wall style alarm may be installed in existing walls when walls are hollow and there are drop ceilings or otherwise accessible areas to route cables. Remove mounting bracket from gang box by drilling out rivets with a 1/4" drill bit. Remove clamp. Attach the two metal tabs supplied with gang box to the center top and bottom positions on front of gang box. (attach tabs so that indentations are inside and facing to rear of gang box) Cut an opening 5 3/4" lg. x 3 7/8" high in wall at desired alarm site. Attach gang box into opening with switch box supports (Madison Straps) which are installer supplied. Refer to regular wall style installation above to complete. Test alarm.

TRANSFORMER INSTALLATION

Remote transformer is designed to connect to a 4" x 4" junction box with a 120 volt AC supply. Connect the 120 volt primary side of transformer to 120 Vac supply with wire nuts. Connect the 12 volt AC secondary side of transformer to the 2 conductor wires of alarm cable with wire nuts. Secure cover to junction box. Transformer must be mounted as to be OUTSIDE junction box. Refer to diagram on page 6. (SEE SPECIAL NOTE UNDER DESK ALARM INSTRUCTIONS REGARDING THE OPTIONAL PLUG IN AC ADAPTER TYPE TRANSFORMER)

ALARM TEST: Refer to page 8 of manual for alarm test instructions. Note: If pipeline system and gas tanks are not installed, pressure switch contacts on manifold may be bridged to determine alarm circuit is connected properly. Alarm test procedure described on page 8 must still be performed after the system is completely installed.

INSPECTION

DEALERS INSTRUCTIONS

1. VERIFY THAT SYSTEM HAS BEEN LEAK TESTED
2. INSTALL COVER PLATES ON OUTLET STATIONS
3. INSTALL ALL SECONDARY EQUIPMENT (flowmeters, mounting brackets, etc.)
4. TEST FOR CROSSED LINES
 - a. use quick connect without machine attached to bleed system to zero
 - b. connect oxygen and nitrous oxide cylinders to manifold
 - c. chain cylinders to wall
 - d. turn on oxygen ONLY (make sure nitrous oxide pressure is zero)
 - e. insert quick connects into outlet stations
 - f. gas should flow ONLY from oxygen outlets
 - g. turn off oxygen cylinder
 - h. bleed oxygen line pressure to zero
 - i. repeat procedure with nitrous oxide
5. TEST ALARM AND ADJUST REGULATORS
 - a. remove 9/16" cap nut located on front of regulator
 - b. insert 3/16" allen wrench into brass screw on regulator
 - c. turn on alarm
 - d. establish 5 liter flow of oxygen on flowmeter
 - e. turn allen wrench counter clockwise until line pressure is just below 40 PSI
 - f. oxygen "LO" indicator light and audio signal should come on, depress reset button to cancel audio signal
 - g. turn allen wrench clockwise until line pressure is just above 65 PSI
 - h. oxygen "HI" indicator light and audio signal should come on, depress reset button to cancel audio signal
 - i. adjust oxygen pressure back to 50 PSI
 - j. adjust other oxygen regulator(s) to 50 PSI if required
 - k. replace cap nuts on regulators
 - l. repeat procedure with nitrous oxide
6. PLACE INSTRUCTION MANUAL AND OPERATING INSTRUCTIONS ON WALL NEXT TO MANIFOLD
7. INSURE WARRANTY CARDS ARE COMPLETED AND RETURNED TO BELMED
8. DEMONSTRATE SYSTEM TO DOCTOR

SERVICE

NOTE: With exception of bulb replacement, all service on manifold system should be performed by a qualified, experienced service person ONLY.

REGULATOR ADJUSTMENT

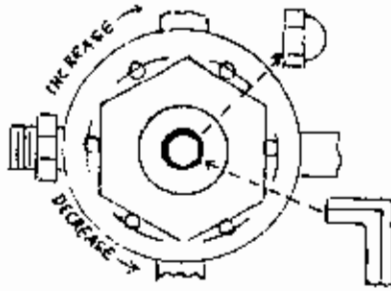

Regulator line pressure should be 50 PSI at full cylinder pressure. Regulators should be adjusted with gas flowing. Connect gas machine to gas pipeline and establish a 5 liter flow. Remove 9/16" cap nut located on front of regulator, insert 3/16" allen wrench into brass screw. Turn clockwise to increase pressure and counter clockwise to decrease pressure. When line pressure is 50 PSI, remove allen wrench and replace cap nut.

PRESSURE SWITCH ADJ.

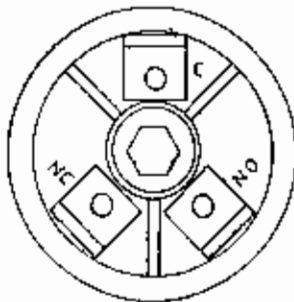

NOTE: Top view drawing of Pressure Switch at left shows both the high (NO) terminal and low (NC) terminal for illustration purposes only. Pressure switches on manifold will have only one terminal, either high (NO) or low (NC). First remove soft rubber cover from center of switch by gently prying off with small flat bladed screwdriver or similar tool. This will allow access to 7/32" hex socket. Replace cover after adjustment.

HIGH PRESSURE ADJUSTMENT (Normally open terminal)

Turn Allen wrench **LEFT** to **INCREASE** pressure.

Turn Allen wrench **RIGHT** to **DECREASE** pressure.

LOW PRESSURE ADJUSTMENT (Normally closed terminal)

Turn **RIGHT** to **INCREASE** setting

Turn **LEFT** to **DECREASE** setting.

NOTE: Right indicates clockwise direction and left counter-clockwise.

Color coding; RED - O2 HI, GREEN - O2 LO, BROWN - N2O HI, WHITE - N2O LO, Black - COMMON

RELIEF VALVE



Relief valve incorporates a preset 75/80 psi spring and is non-adjustable. If valve is leaking, it may be caused by foreign material on seal or poppet seat. To correct, loosen vent cap with 9/16" wrench. Carefully remove vent cap, spring and poppet (seal and retainer will stay in valve body). Wipe poppet seat with clean dry cloth and clean seal with a Q-TIP type cotton swab. Reassemble valve and test by increasing line pressure to 75-80 psi to verify valve relieves properly. Decrease line pressure to 50 psi and verify that valve seats properly and does not leak. If this does not correct problem, replace valve.

ALARM BULB REPLACEMENT

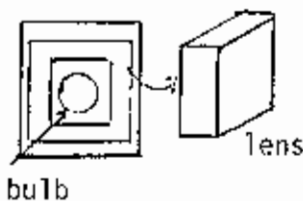

A spare bulb is located within reset button housing. Disconnect alarm from power source. Gently pull on reset lens to remove and expose housing. A tweezer type tool or someone with small fingers can remove bulb by gently pulling toward you. Replacement bulb: GE #7330.

FUSE REPLACEMENT: Fuse is located at right rear of alarm. Replace with 20mm - .5 amp fuse.

OPERATION

NORMAL OPERATION:

At the start of each work day, open all cylinder valves for each gas. **CAUTION: OPEN CYLINDER VALVES SLOWLY.** If more than one cylinder for a gas, read cylinder pressure on each regulator gauge and close those cylinders with the highest pressure. This will leave only the cylinder with lowest pressure open and maintaining the fullest cylinders in reserve. Your gas supplier will supply tags to identify the "in use" and "reserve" cylinders. After turning on proper cylinders, observe line pressure gauge for each gas on manifold. Gauge indicator should be in the white area of dial between LO and HI (preferably at 50 psi). After turning on cylinders and verifying correct line pressure, turn on gas supply alarm. Actuate "PUSH TO TEST" buttons to determine that audio and visual indicators are working normally. If during work day, any cylinder becomes empty, the gas supply alarm will actuate a LO condition. When this occurs, depress reset button on alarm to cancel audio signal, open the reserve cylinder valve and reorder a replacement cylinder from gas supplier. The alarm will automatically reset when normal pressure is restored.

HIGH PRESSURE SIGNAL: Indicates an abnormal pressure condition exists. Turn off system immediately and call a qualified service person.

NOTE: TURN OFF ALL CYLINDERS WHEN FACILITY IS UNATTENDED. Oxygen is a rapid accelerator of fire. With cylinder valves turned off, there is less danger in the event of an unrelated fire. This practice also provides for frequent checks on proper manifold operation and pressures.

REORDERING CYLINDER REPLACEMENT:

OXYGEN: Replace cylinder when gauge on regulator reaches 200 PSI. The gauge will register approximately 2200 psi when fully charged. Oxygen is in a gaseous phase within the cylinder. As the oxygen is used, the pressure indicated on regulator gauge will fall proportionally to the contents. (i.e.: 1500 psi-3/4 full, 1000 psi-1/2 full, etc.) Oxygen is generally supplied in "H" size cylinders and a fully charged cylinder contains 6209 liters of oxygen (244 cu. ft.).

NITROUS OXIDE: Replace cylinder when pressure gauge on regulator reaches 500 psi. The gauge will register approximately 750 psi when fully charged with LIQUID nitrous oxide. As nitrous oxide is used, the liquid converts to a gaseous phase within the cylinder and the gauge will continue to register 750 psi until all liquid converts to a gas within the cylinder. After this occurs, the gauge on regulator will indicate a decrease in pressure as the remaining nitrous oxide is used. Nitrous Oxide is generally supplied in "C" size cylinders and a fully charged cylinder contains approximately 13,800 ltrs. of nitrous oxide. (485 cu. ft.)

NEVER ATTEMPT TO REPAIR OR MAKE CHANGES TO THE SYSTEM. IF IN DOUBT ABOUT PROPER OPERATION, A REPUTABLE SERVICE PERSON, EXPERIENCED WITH MANIFOLD SYSTEMS SHOULD BE CALLED AT ONCE.

NO SMOKING OXYGEN IN USE

MANIFOLD OPERATION

CAREFULLY READ INSTRUCTION MANUAL BEFORE OPERATING
CAUTION—OPEN CYLINDER VALVES SLOWLY

USE NO OIL

- | | |
|---|--|
| 1 | SLOWLY OPEN CYLINDER VALVES, TURN HANDLE COUNTER CLOCKWISE. |
| 2 | IF MORE THAN ONE CYLINDER FOR EACH GAS, OPEN ONLY THE "IN USE" CYLINDERS, KEEPING FULL CYLINDERS IN RESERVE. |
| 3 | VISUALLY CHECK PRESSURE GAUGE ON REGULATOR. REPLACEMENT CYLINDERS SHOULD BE ORDERED FROM GAS SUPPLIER WHEN OXYGEN PRESSURE IS 200 PSI AND NITROUS OXIDE PRESSURE IS 500 PSI. |
| 4 | VISUALLY CHECK LINE PRESSURE GAUGE ON MANIFOLD. PRESSURE INDICATOR SHOULD BE IN WHITE AREA BETWEEN "LO" AND "HI". |
| 5 | TURN ON GAS SUPPLY ALARM. ACTUATE EACH TEST BUTTON TO DETERMINE VISUAL AND AUDIBLE INDICATORS ARE WORKING. |
| 6 | WHEN UNATTENDED, TURN OFF ALARM AND CLOSE ALL OPEN CYLINDERS. TURN HANDLE CLOCKWISE. |
| * | NEVER ATTEMPT TO REPAIR OR MAKE CHANGES TO THE SYSTEM. IF IN DOUBT ABOUT PROPER OPERATION, A REPUTABLE SERVICEMAN, EXPERIENCED WITH MANIFOLD SYSTEMS SHOULD BE CALLED AT ONCE. |



BELMED INC.

887 Delta Rd. • Red Lion PA 17356

(717) 246-5500 • Fax: (717) 246-7586

E-Mail: bmi@belmedinc.com

Web Site: www.belmedinc.com